

**Tools Required:**

- 7/16" nut driver or socket
- Flathead screwdriver.
- Requires two people for assembly.
- Approximate assembly time: 15 to 30 minutes per unit.

**Note: Number of shelves per unit varies depending on unit purchased.**

**Note: Back and side panels are split to make them easier to ship. Depending on the height of the unit purchased, a number of different panels will be included. Refer to side panel chart in Step 2.**

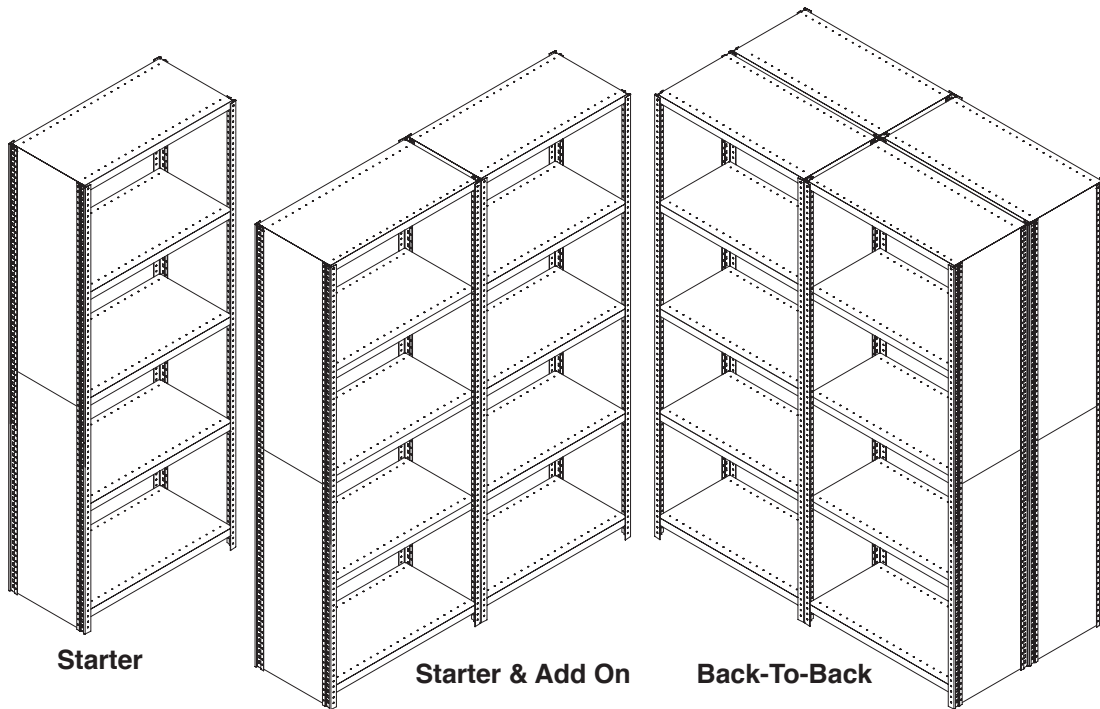

Starter

Starter & Add On

Back-To-Back

**1.** Create the right side of the shelving unit by laying the uprights side-by-side on a flat surface.

**Important: One side of the uprights is longer than the other, and contains two sets of holes. When laying the uprights side-by-side, this long side should be on the floor, and the short side should be facing up.**

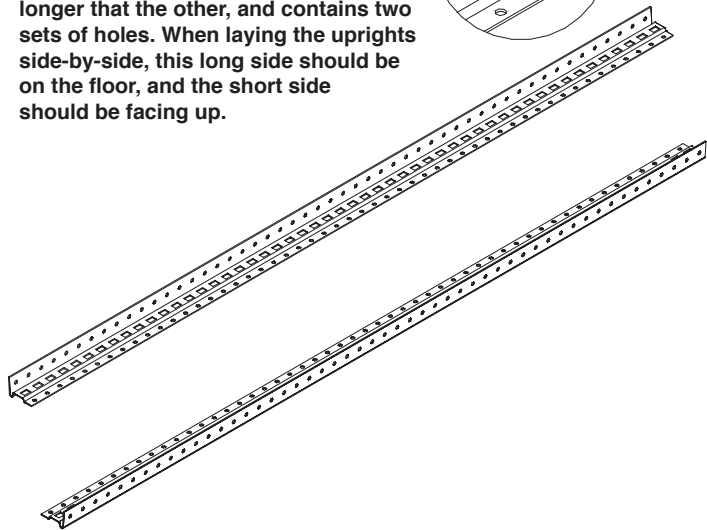
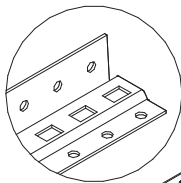

**2.** Place end panels (see chart below) on the uprights.

**2a.** Used for most single-unit installations. Also used on each end of a row of units. Make sure the end panel fits into the inset of the uprights.

**2b.** Used as the center, joining upright bank of units. The end panel should be sandwiched between the upright posts.

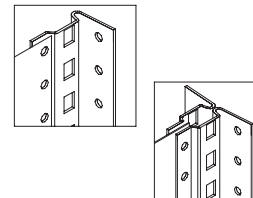

Ht.	Panels
39"	(1) 39"
63"	(1) 39" (2) 13"
73"	(2) 39"
85"	(2) 39" (1) 13"
97"	(2) 39" (2) 13"

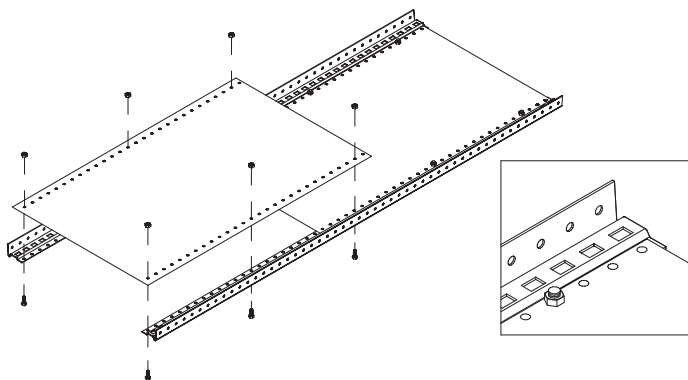
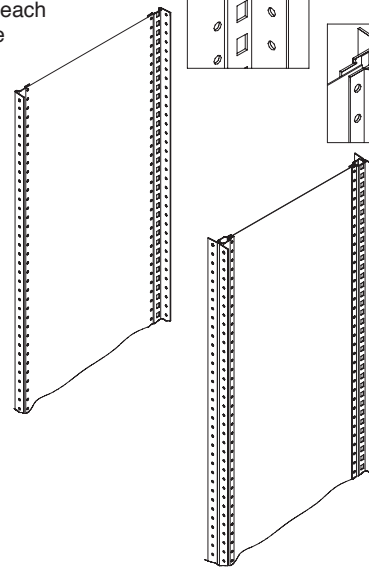

**3.** Bolt the panels into the small holes near the edge of both uprights using 1/4-20 x 5/8" bolts and nuts. Leave 16 or 17 holes (16 or 17 inches) between each bolt, as shown in the drawing. Also, if you can pre-determine where you want your shelf levels to be, try to position the bolts where they will not interfere with the shelves; this will avoid having to move them later. Finger tighten only at this point, as binding may occur during shelf placement if side panels are attached too tightly.

Note: The three holes at the top of the upright must be left open, as shown, to avoid interference with the top shelf.

**4.** Repeat steps 1-3 for the left uprights.

**5.** Lay the unit back on a flat surface and attach one end to it using  $\frac{1}{4}$ "-20 x  $\frac{5}{8}$ " bolts and nuts spaced 16 or 17 inches apart, as described in step 3. Once again, leave the top three holes empty to allow for the top shelf.

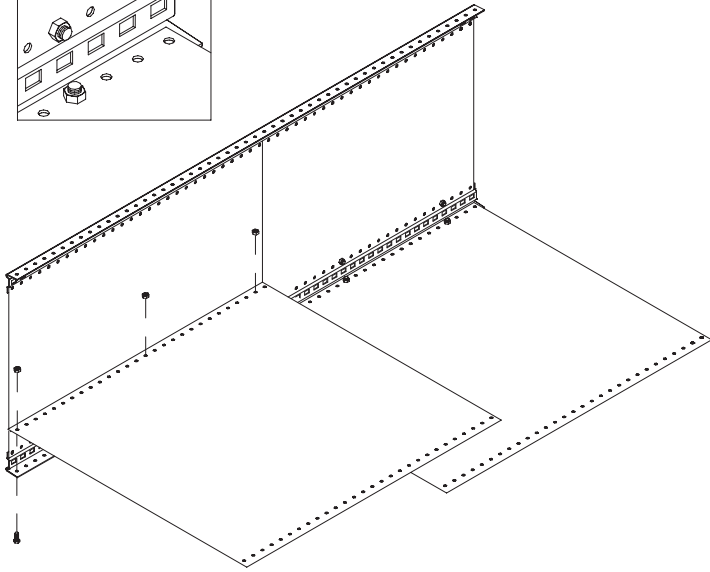
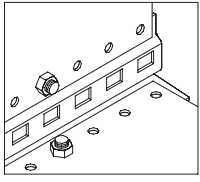

**6.** Have an associate help you by holding the first upright up as you attach the other upright in the same way as the first.

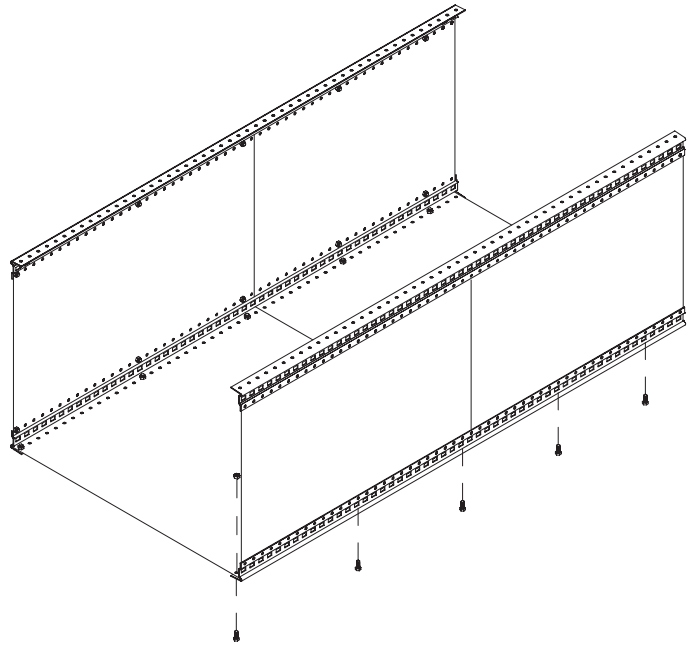

**7.** Bolt the top shelf.

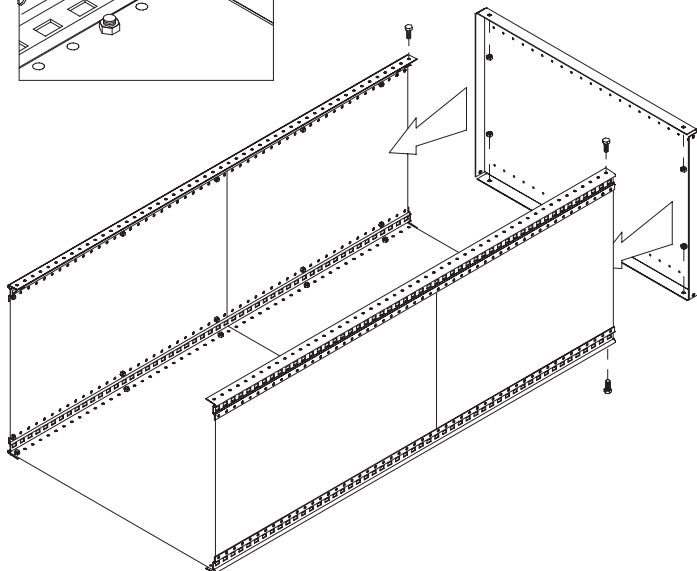
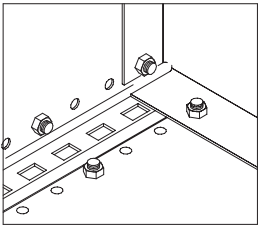

**8.** Bolt the bottom shelf using the third hole from the bottom.

**Note:** Once the bottom shelf is in place, use the help of an associate to carefully lift the top end of the unit so that the shelving unit is standing upright.

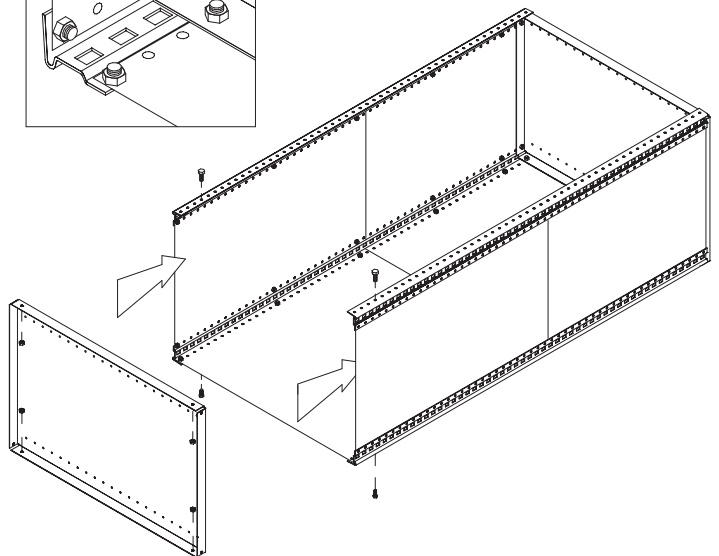
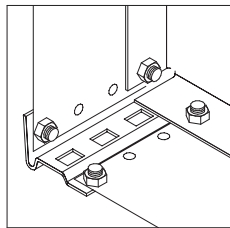

**9.** Position the shelf clips according to your desired shelf height, and place the shelves over the clips. Keep in mind, while placing the clips, that the post hole pattern of two round holes and then one square hole, repeated every 3", can greatly help in positioning the clips at the same level.

**Please Note:** Some shelves, depending upon placement, may require repositioning of of the back- and end-panel bolts in order to insert the shelf.

**10.** Tighten-up all bolts and nuts on the side panels.

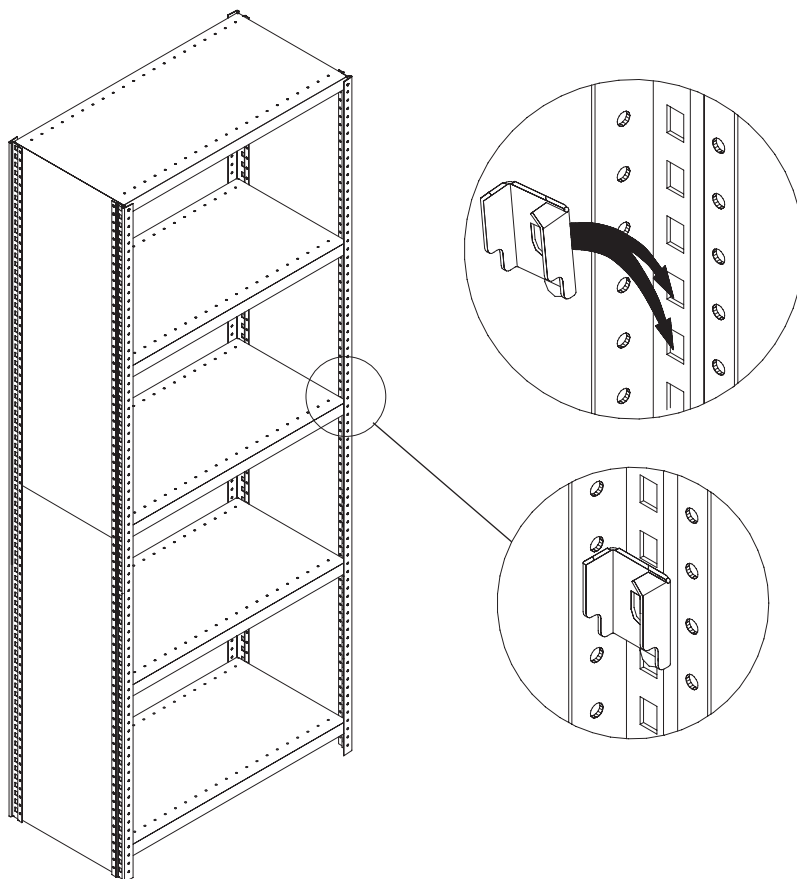

**11.** For added strength, place two  $\frac{1}{4}$ -20 x  $\frac{5}{8}$ " bolts and nuts (not included) through each corner of each shelf, and into the small holes of the upright.

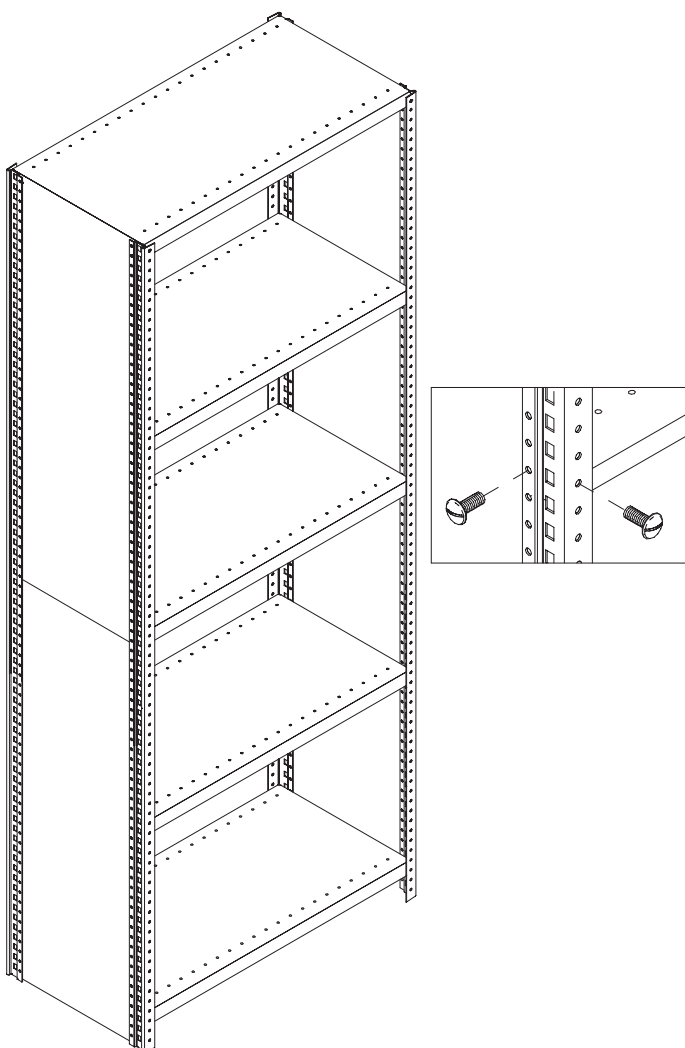

**12.** If more than one unit is to be used in a row, assemble a new unit end, and then connect this new end to the existing unit (which you already built with the proper uprights if you followed the instructions in step 2) with a top and bottom shelf. After the end is connected, you can then insert the back by bending it slightly and wedging it between the posts and the shelves. Bolt in place the same as you did for the first unit. Once the back is in place, you may insert the remaining shelves.

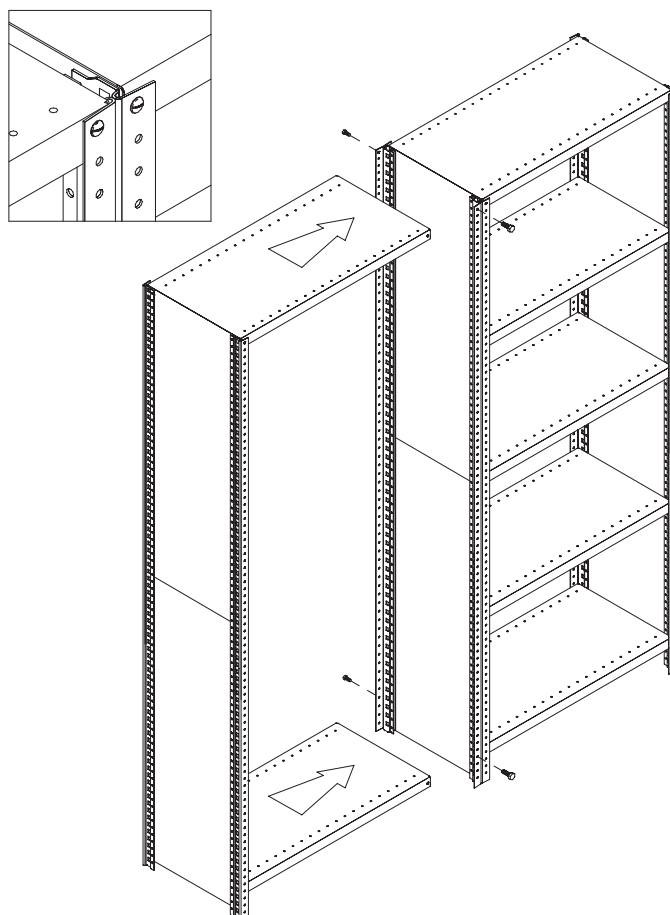

**13.** If two units are to be placed back-to-back, and you have only one back panel, the two units may share the same back panel by attaching it on the OUTSIDE of the uprights. If you have ordered two units, each with a back, you can use both backs on the INSIDE of the uprights.

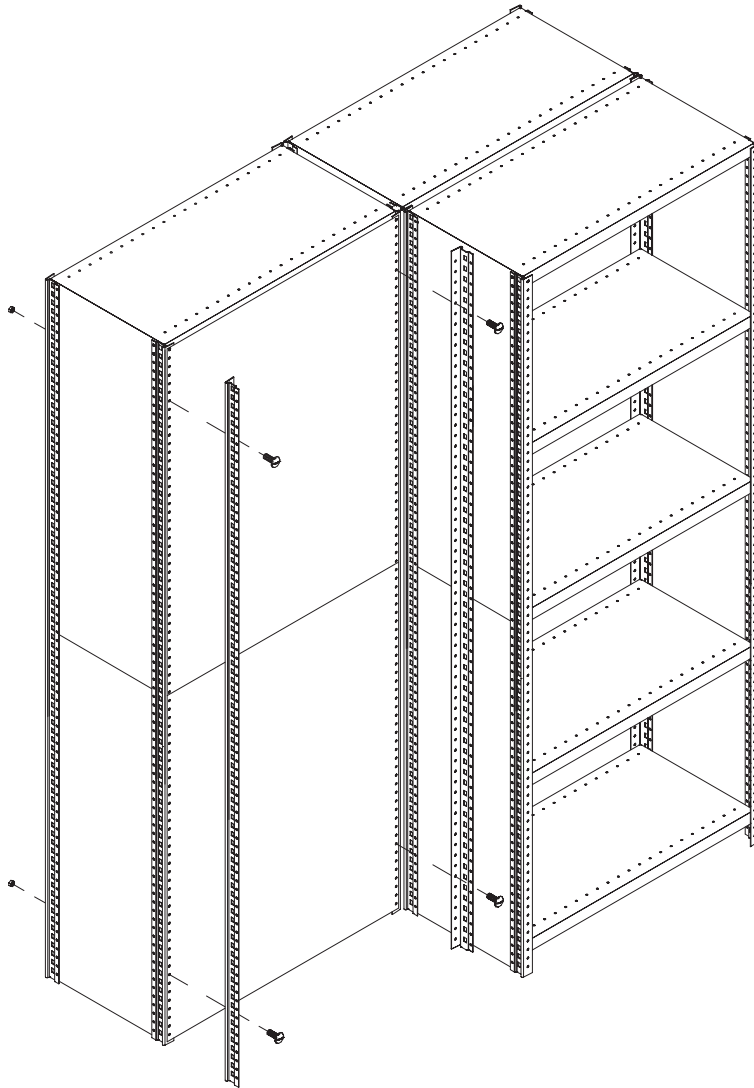

**1a.**

**14.** For added shelf strength, insert shelf reinforcement channel 1a. (sold separately) into bottom of shelf. Place on an angle and turn into shelf channels as pictured above.

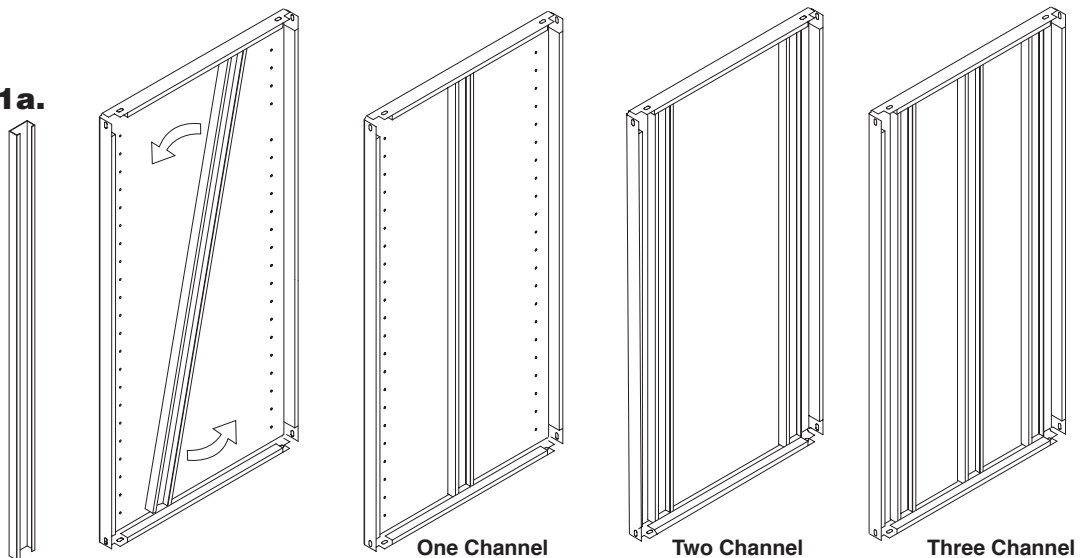

 **GLOBAL**<sup>®</sup>  
globalindustrial.com

Customer Service  
1-800-645-2986

**1-800-645-1232**